

# ÀÒ2327

## ALARM DOSIMETER

Flexible and reliable multi-channel stationary radiation monitoring system to perform environmental and area radiation monitoring of radiation-sensitive rooms and targets

From 1 to 10 control posts  
in one alarm dosimeter  
From 1 to 32 alarm dosimeters  
in one system

### Features

- Gamma and neutron radiation smart probes
- Independent measuring in each channel within wide gamma and neutron radiation dose rate and neutron radiation flux density ranges
- Audible and visual alarm at threshold exceeding for each smart probe
- High reliability
- Failure diagnostics
- Database of dose rate values and alarm threshold excesses
- Applied software to display current radiation environment in real time
- Backup power unit
- Mobile one-channel design

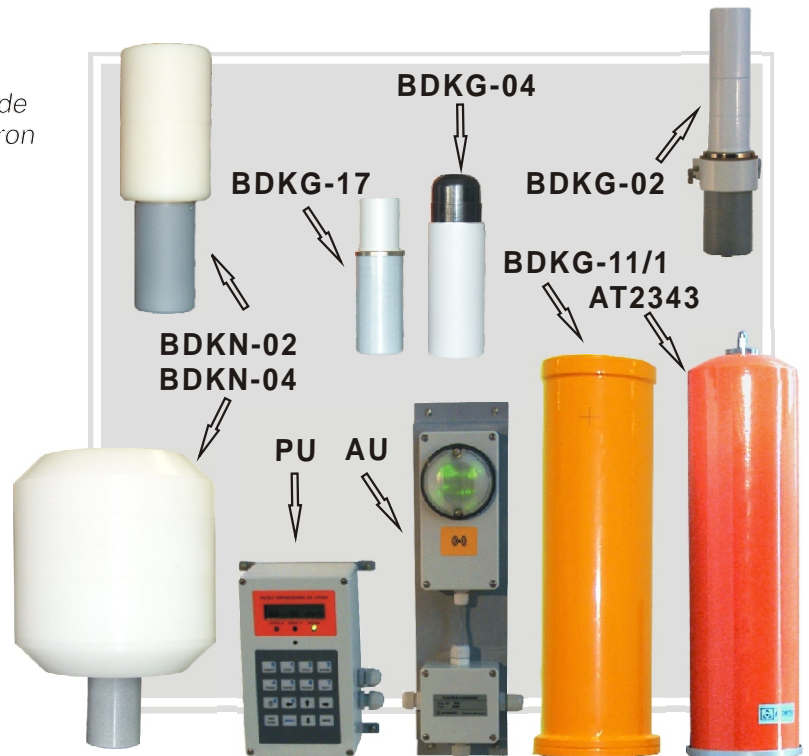

### Application

- Nuclear industry
- Radiology
- Industry
- Radioisotope and dosimetry laboratories
- Civil defense

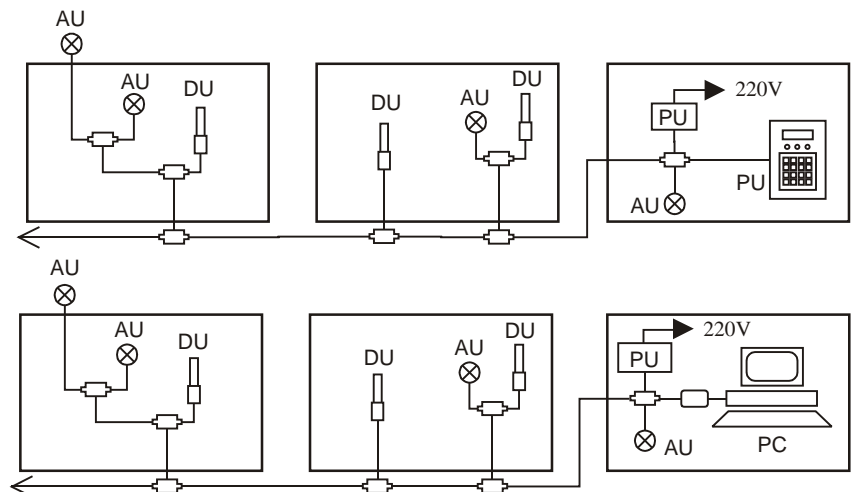

The alarm dosimeter may consist of gamma radiation smart probes (AT2343, BDKG-02, BDKG-04, BDKG-11/1, BDKG-17) and neutron radiation smart probes (BDKN-02, BDKN-04) (SP). The smart probes are completely independent instruments measuring gamma and neutron radiation dose rate and neutron radiation flux density every 2 s and triggering audible and visual alarm. One or several audible and visual alarm units (AU) may be connected to each smart probe to notify the staff in the case of radiation hazard. Data from smart probes are transferred to the processing unit via RS-485.



# ATOMTEX

INSTRUMENTS AND TECHNOLOGIES FOR  
NUCLEAR MEASUREMENTS AND RADIATION MONITORING

The processing unit displays measured values of the selected smart probe and real time. Alarm threshold exceeding or a failure of any system units is accompanied by audible and visual signals showing symbolically the problem location on the display. The processing unit is intended to setup thresholds for each smart probe, monitor smart probe state, correct the real-time clock, protect several service functions with a password and review dose rate and threshold exceeding history of any smart probe.

When PC is used as a part of a radiation monitoring system, applied software running under Windows 2000 is intended to configure the system, read out readings and process them.

The map of the monitoring area or target and dose rate values as charts and tables in measuring posts are displayed on PC. Alarm threshold exceeding in any smart probe or failure of any system units are displayed on PC as color zones and accompanied by audible alarm. Measured dose rate values in measuring post are stored in a database (Microsoft Access-2000).

## ***Specification***

<b>Number of smart probes</b> in one alarm dosimeter .....	from 1 to 10	<b>Intrinsic measurement error</b> .....	± 20 %
<b>Number of alarm dosimeters</b> in one radiation monitoring system connected to PC .....	32	<b>Operating temperature range</b>	
		smart probes .....	-30 ÷ +50 °Ñ
		other units .....	+5 ÷ +40 °Ñ
<b>Ambient dose equivalent rate measuring range</b>		<b>Interface</b>	
gamma radiation		(cable communication) .....	RS 485
BDKG-02 .....	0.1 µSv/h - 10 Sv/h	<b>3-level visual and audible alarm</b>	
BDKG-04 .....	0.05 µSv/h - 10 Sv/h	<b>Maximum distance</b> between a smart probe and the processing unit (cable communication) .....	1000 m
BDKG-11/1 .....	0.01 - 100 µSv/h	<b>Protection class</b>	
BDKG-17 .....	1 mSv/h - 100 Sv/h	detection units .....	IP57
neutron radiation		other components .....	IP50
BDKN-02 (from Pu-Be sources) .....	0.1 µSv/h - 10 mSv/h	<b>Radio disturbance</b>	
BDKN-04 (0.025 eV - 14 MeV) ..	0.1 µSv/h - 10 mSv/h	EN 55022:1998	
<b>Gamma radiation absorbed dose rate</b> measuring range (AT2343) .....	25 nGy/h - 10 Gy/h	<b>Electromagnetic compatibility</b>	
<b>Neutron radiation flux density</b> measuring range BDKN-02, BDKN-04 .....	0.1 - 10 <sup>4</sup> neutron/(cm <sup>2</sup> ·s)	IEC 61000-4-11:2004	
<b>Sensitivity</b> on <sup>137</sup> Cs		IEC 61000-4-4:2004	
BDKG-02 .....	4.0 cps/µSv·h <sup>-1</sup>	IEC 61000-4-2:2001	
BDKG-04 .....	70 cps/µSv·h <sup>-1</sup>	IEC 61000-4-3:2005	
BDKG-11/1 .....	1970.0 cps/µSv·h <sup>-1</sup>	<b>Power supply</b>	
BDKG-17 .....	0.004 cps/µSv·h <sup>-1</sup>	AC mains .....	220 (+22;-33) V; frequency 50 (±2) Hz
AT2343 .....	15000 cpt/µSv	Accumulator battery at emergency ....	12.6 (+1.3;-1.6) V or 25.2 (+2.6;-3.2) V
<b>Neutron sensitivity</b> from Pu-Be sources			
BDKN-02 .....	1.15 cps/(neutron/s <sup>-1</sup> ·cm <sup>-2</sup> )		
BDKN-04 .....	1.5 cps/(neutron/s <sup>-1</sup> ·cm <sup>-2</sup> )		
<b>Energy sensitivity response</b> respect to <sup>137</sup> Cs .....	not more than +35 ÷ -25 %		
<b>Gamma radiation energy range</b>			
BDKG-02, BDKG-17 .....	60 keV - 3 ħ eV		
BDKG-04 .....	15 keV - 3 ħ eV		
AT2327 .....	50 keV - 3 ħ eV		
<b>Detecting neutron radiation</b> energy range .....	2.5 · 10 <sup>-5</sup> keV - 14 ħ eV		

**Complete set:** processing unit, smart probes AT2343, BDKG-02, BDKG-04, BDKG-11/1, BDKG-17, BDKN-02, BDKN-04, alarm units, terminal-block boxes, AC adapter, Manual, complete of assembly parts and accessories.  
Backup power unit, applied software, PC and interface adapter are option and they are supplied **on additional order.**

Alarm dosimeter AT2327 has pattern approval certificates of Republic of Belarus, Russian Federation, Ukraine and Kazakhstan.  
It complies with IEC 61017-7 International standard requirements. They also conform with the 89/336/EEC directive complying with EN 61000-4-3, EN 61000-4-2, EN50371, EN61010-1 standard requirements.

**5, Gikalo st., 220005 Minsk,  
Republic of Belarus  
tel. +375 17 2928142  
tel. / fax +375 17 2928142, 2882988  
e-mail: info@atomtex.com  
http://www.atomtex.com**



# **ATOMTEX**